

Adapter-Platte für Braeker-Lock



Adapter-Plate for Braeker-Lock

Adapter-Platte Braeker-Lock

Adapter-Platte Braeker-Lock



1

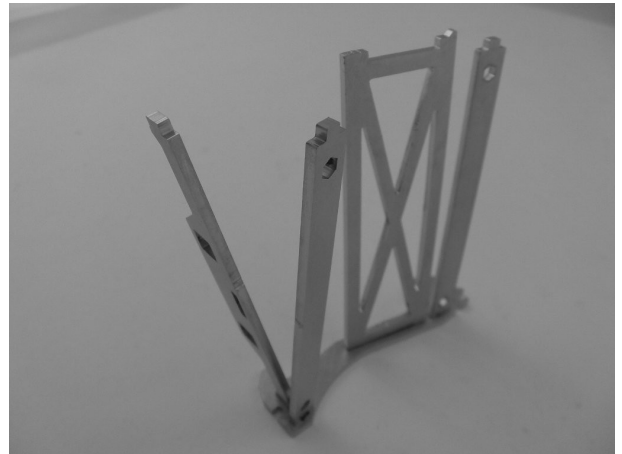

4



2

! separaten MONTAGEHINWEIS BEACHTEN !
! FOLLOW additional INSTALLATION INSTRUCTION !

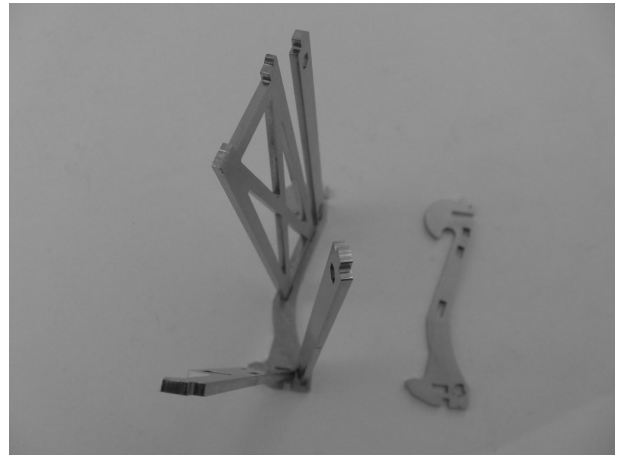

5

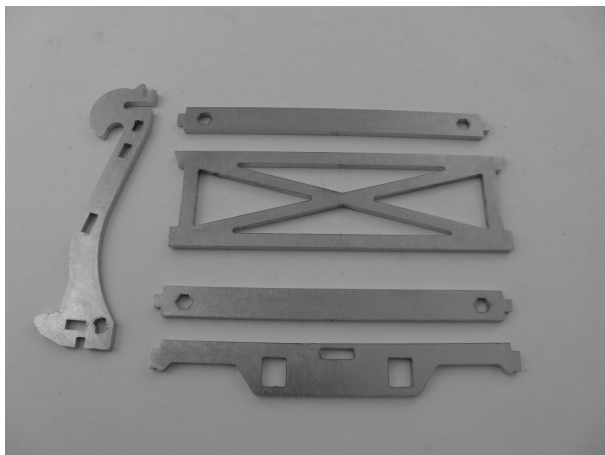

3



6

! ERST dann KLEBEN, wenn HINWEIS in Bauanleitung !
! ONLY GLUE, if noted in Instruction manual !

Adapter-Platte
Braeker-Lock

Adapter-Platte
Braeker-Lock

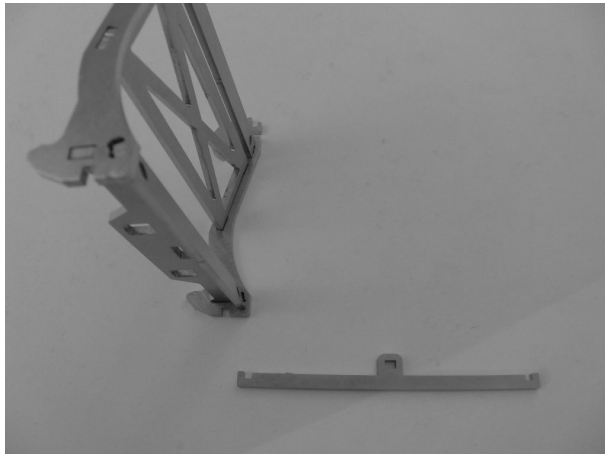

7

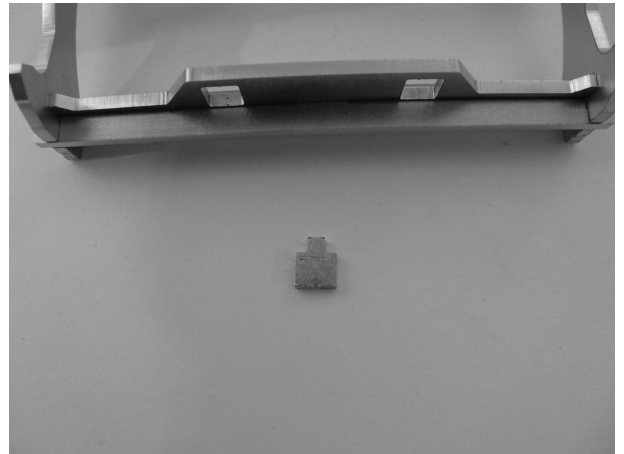

10

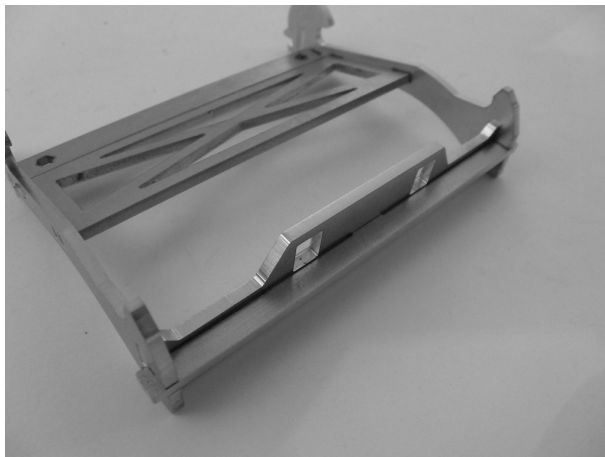

8

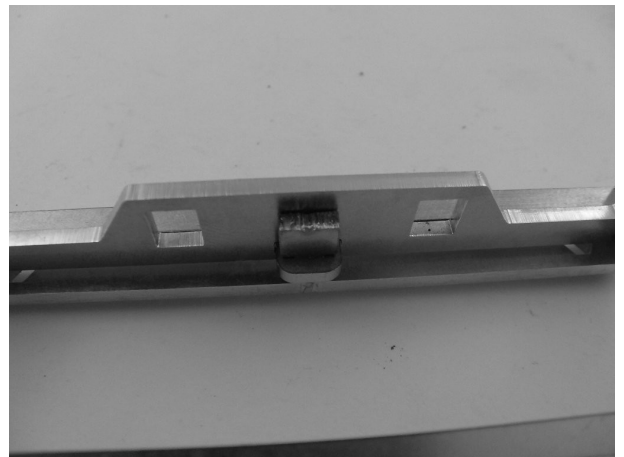

11



9

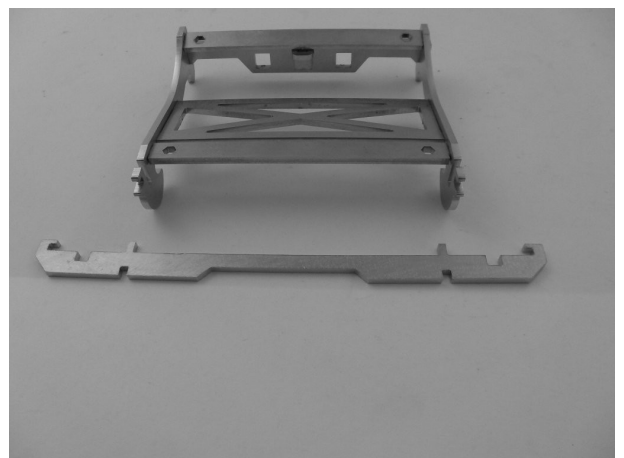

12

Adapter-Platte
Braeker-Lock

Adapter-Platte
Braeker-Lock

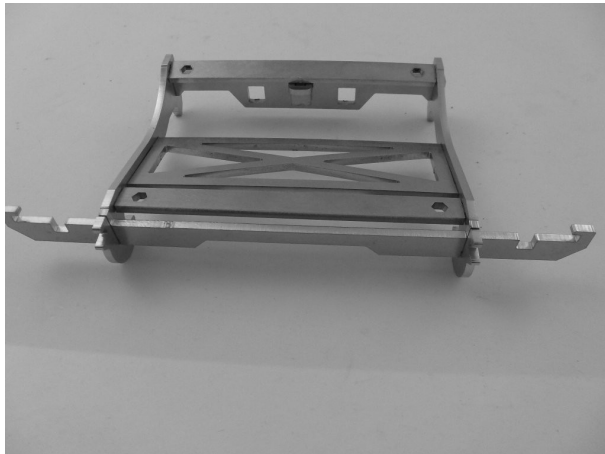

13

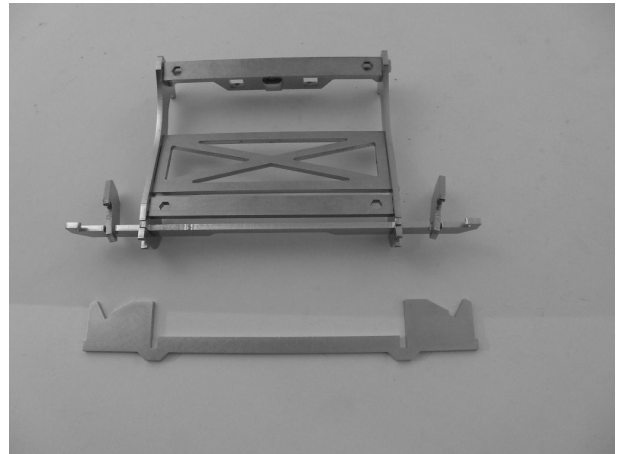

16

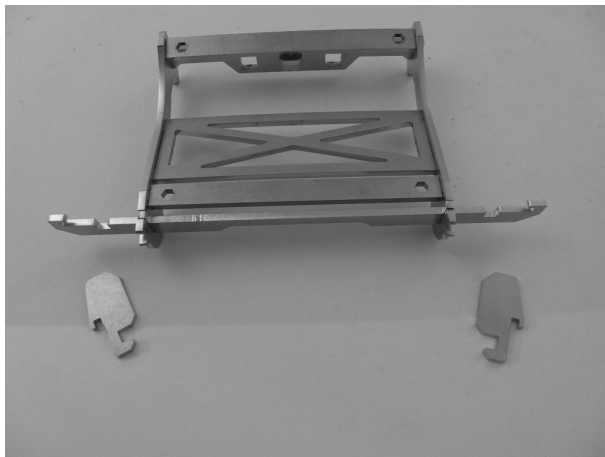

14

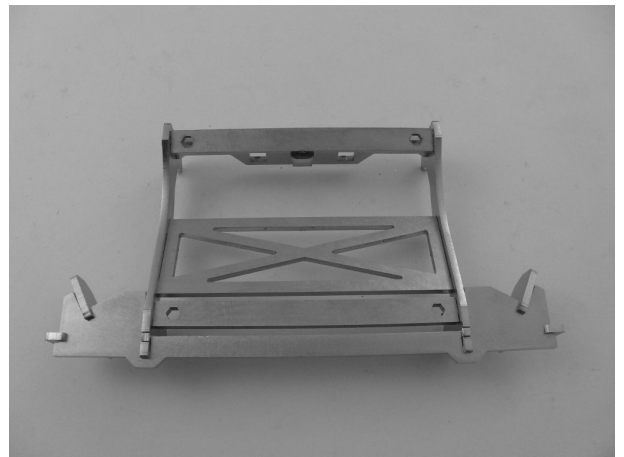

17

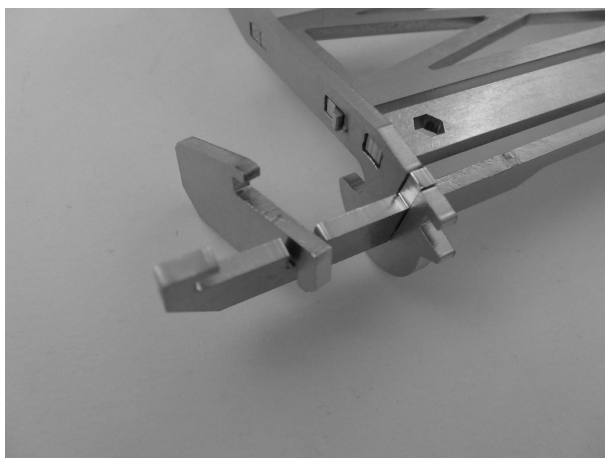

15

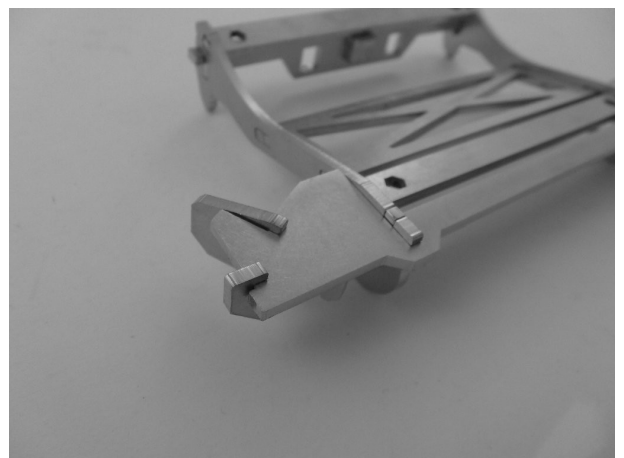

18

Adapter-Platte
Braeker-Lock

Adapter-Platte
Braeker-Lock

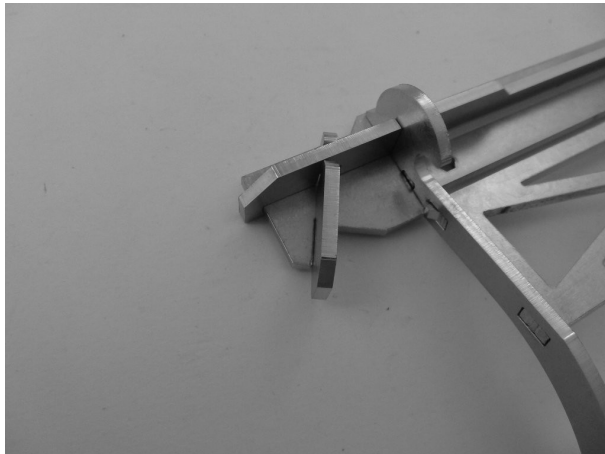

19

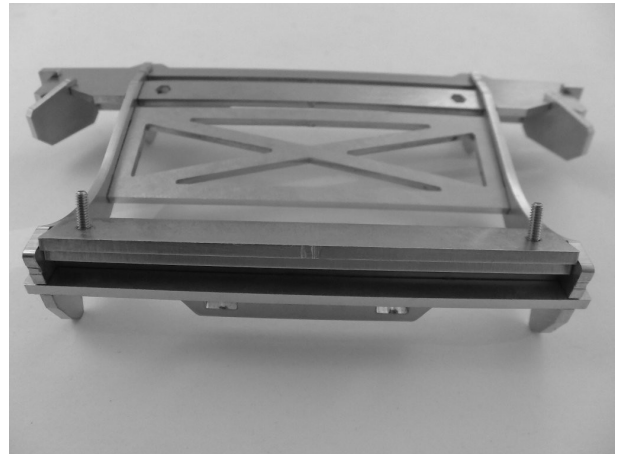

22

Nur zum Verständnis der späteren Positionierung
Only for demonstration of the position later on

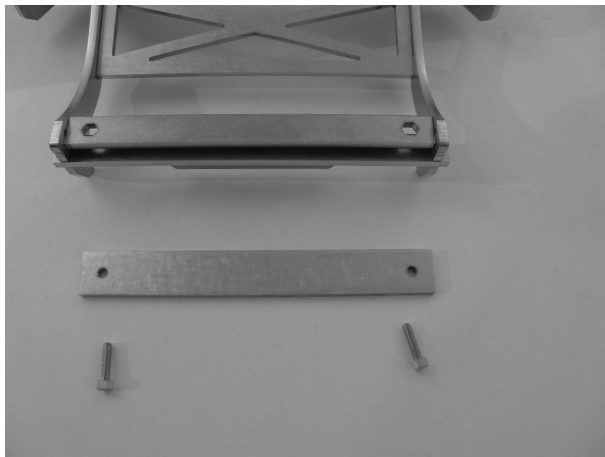

20

Schrauben sind zur Befestigung Ihres Anbaugerätes
Screws are to fix your attachment equipment



23



21



24

Adapter-Platte Braeker-Lock

Adapter-Platte Braeker-Lock

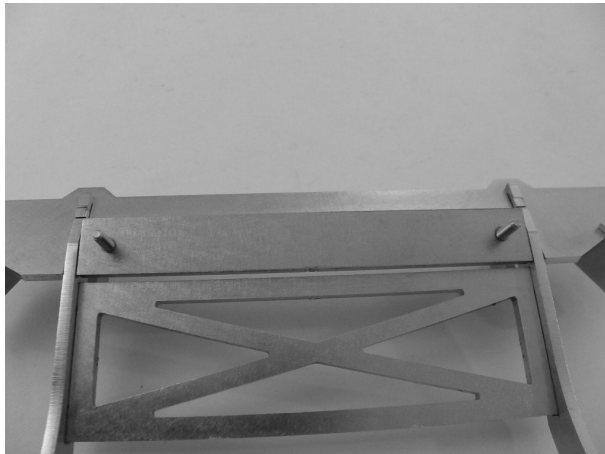

25

Nur zum Verständnis der späteren Positionierung
Only for demonstration of the position later on

Der Zusammenbau der Adapter-Platte ist hiermit
beendet. Gelebt wird erst nach der Montage der
Adapter-Platte an die Erstausrüsterschaufel
The assembly of the Adapter-Plate is finished now.
Use the adhesive after the assembly of the
Adapter-Plate and your OEM bucket



26

Die Anschlagplatten sind pendelnd von 180° bis 128°
gelagert

The locating plate are pivoted between 180° to 128°

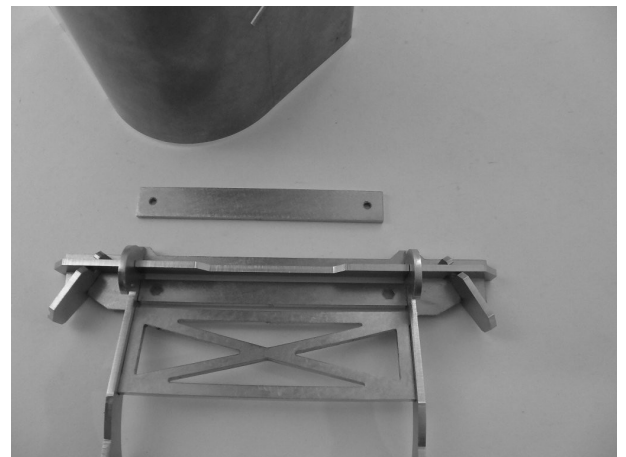

28

Das übrig gebliebene Teil wird als Zeichen-Schablone
benutzt

The left part is a jig to mark the bore holes

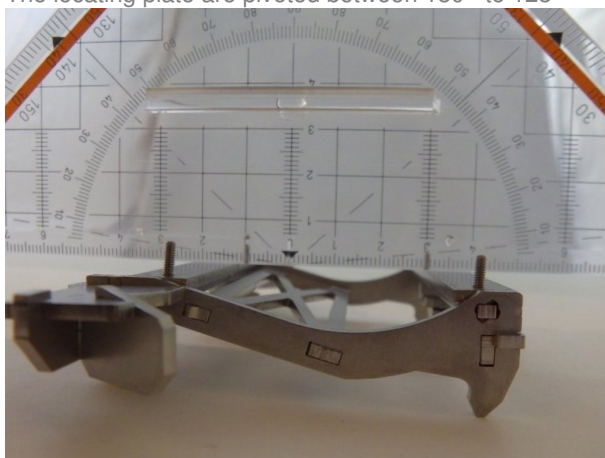

27



29

Ihre Erstausrüsterschaufel muss glatt sein

Your OEM bucket must be flat

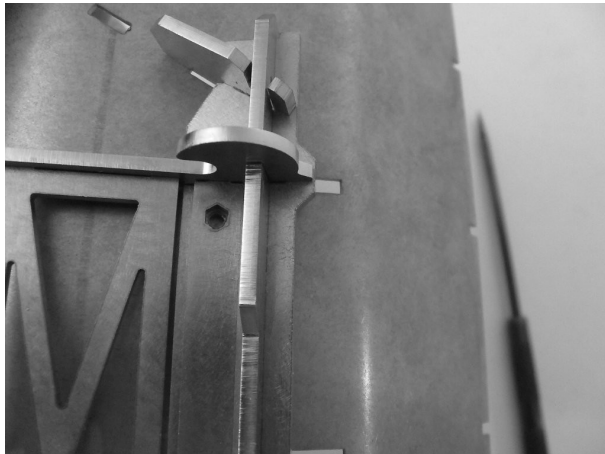

30
Schablone mittig zu den Sechskantlöchern
unterschieben
Push jig central under the hexagonal hole

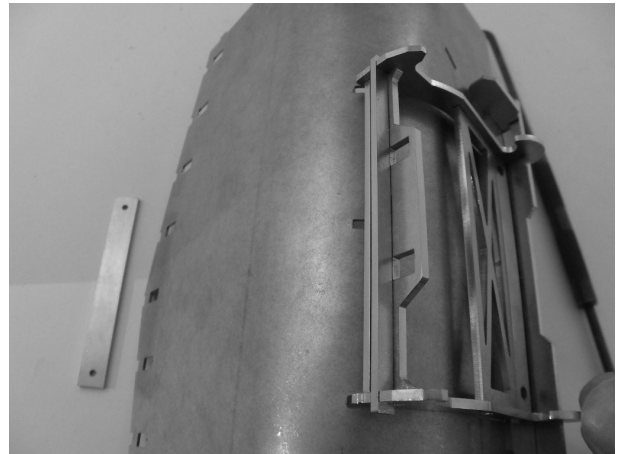

33



31
2x Bohrungen auf der Schaufel anreißen
2x Mark bore with scriber



34
Schablone mittig zu den Sechskantlöchern
unterschieben
Push jig central under the hexagonal hole

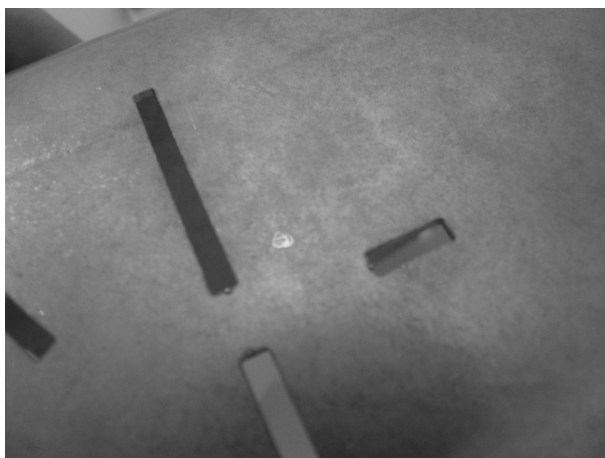

32

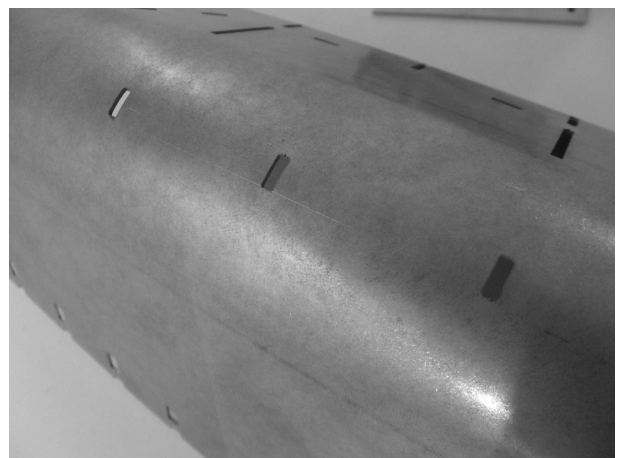

35
Unterkante der Schablone anreißen
Scribe bottom edge of jig

Adapter-Platte Braeker-Lock

Adapter-Platte Braeker-Lock

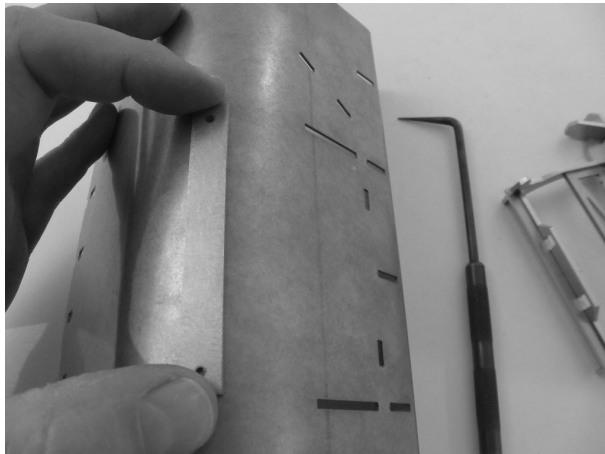

36
Schablone an der Reißlinie anhalten und Bohrungen anreißen
Hold jig to the line and scribe the bores

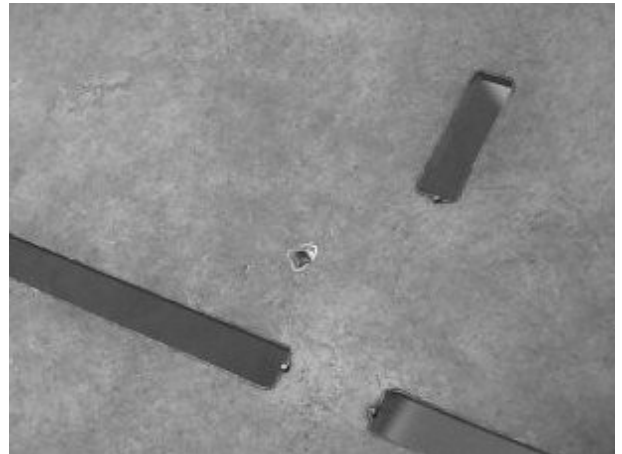

39

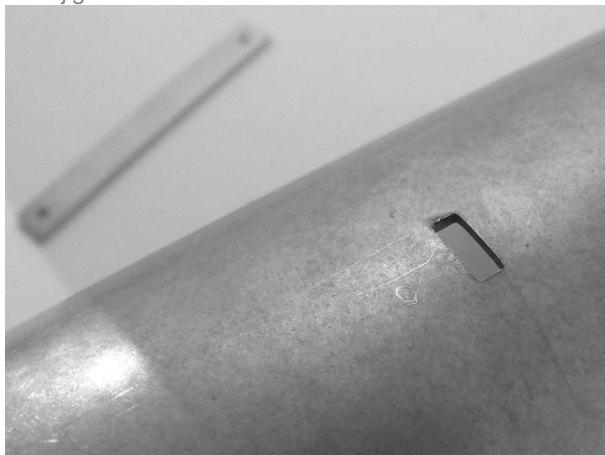

37



40



38
Lochmarkierungen können
Centre punching of bore marks

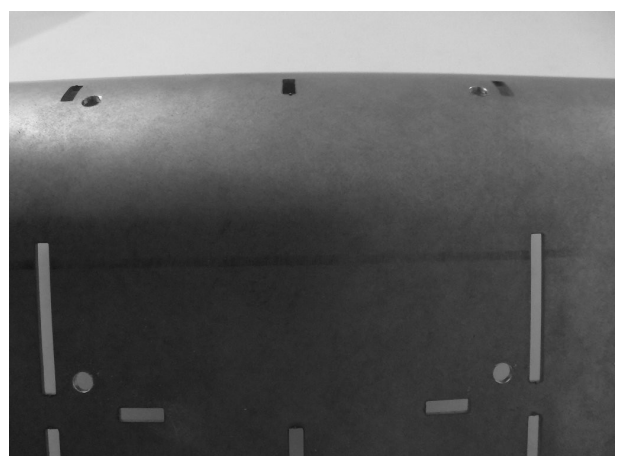

41

Adapter-Platte Braeker-Lock

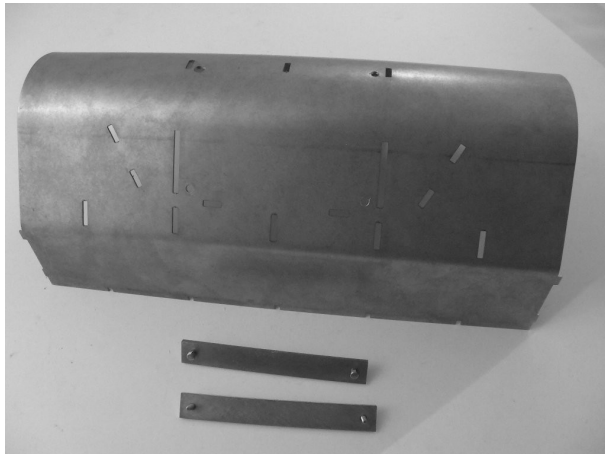

42

Adapter-Platte Braeker-Lock

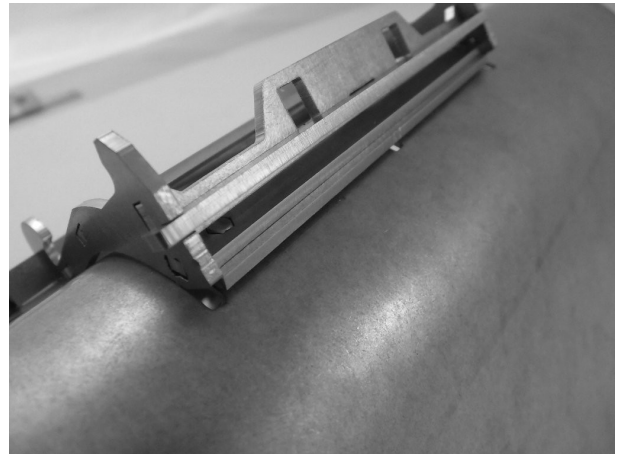

45

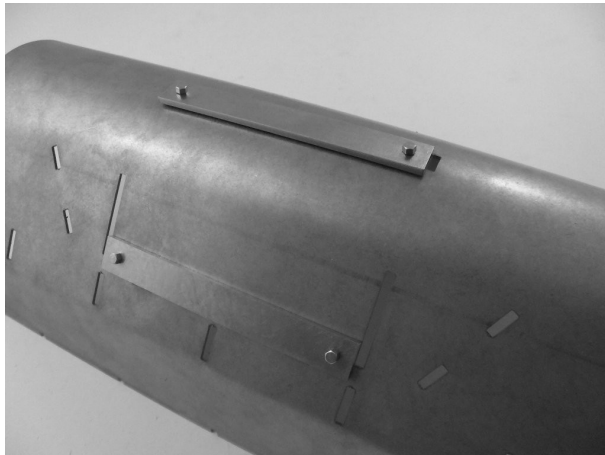

43

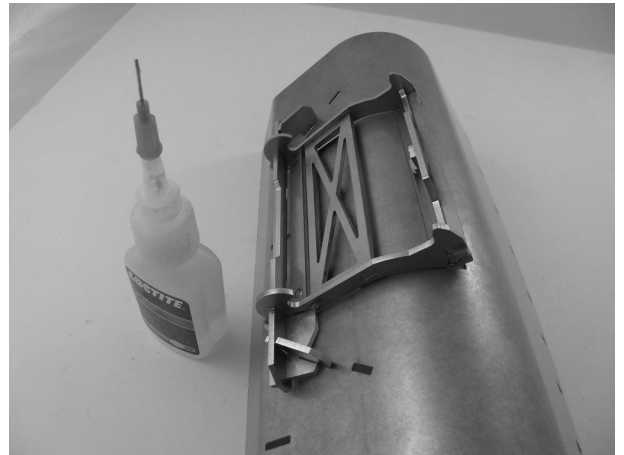

46

**! ERST JETZT KLEBEN !
! ONLY GLUE NOW !**



44

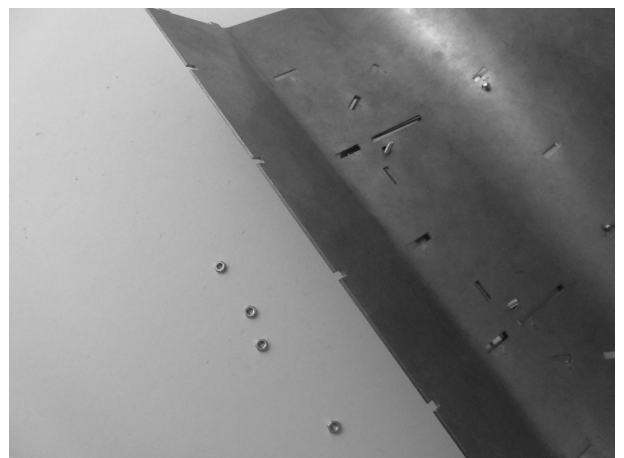

47

Adapter-Platte
Braeker-Lock

Adapter-Platte
Braeker-Lock

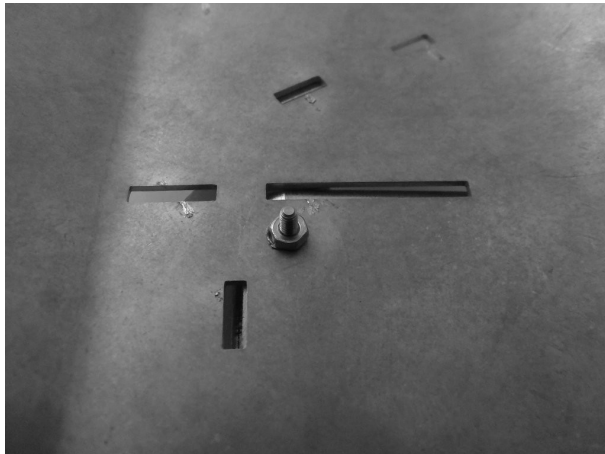

48

Viel Freude beim Einsatz Ihrer Erstausrüsterschaufel mit dem Braeker-Lock

Have fun operating with your OEM bucket and the Braeker-Lock

Adapter-Platte Braeker-Lock

Adapter-Platte Braeker-Lock

Stückliste:

1St Blech Baugruppe Adapter-Platte
4St Schraube M2 x 8 mm
4St Mutter M2

Bill of material:

1pc assembly group Adapter-Plate
4pc screw M2 x 8 mm
4pc nut M2



zusätzlich wird benötigt:

Spezialkleber für Metalle

additional needs:

Special glue for metal